



INTAKE SYSTEMS FOR VEHICLES LISTED ARE 50 STATE LEGAL. SEE KNFILTERS.COM FOR CARB STATUS ON EACH PART FOR A SPECIFIC VEHICLE.

# INSTALLATION INSTRUCTIONS

## 77-1568KTK

### RAM

2014-18 Ram 2500 / 3500

V8-6.4L

NOTE: This kit was not designed to fit vehicles with a body lift.

#### TOOLS NEEDED:

- Flat blade screw driver
- T20 torx key
- 4mm allen key
- 3mm allen key

#### PARTS LIST:

| Description                   | Qty. | Part #  |
|-------------------------------|------|---------|
| A HEAT SHIELD                 | 1    | 073192A |
| B WASHER; 6MM FLAT            | 2    | 08269   |
| C WASHER, M6 SPLIT LOCK       | 2    | 1-3025  |
| D BOLT; M6 X 1 X 16MM         | 2    | 07730   |
| E HOSE CLAMP #64 STAINLESS    | 3    | 08645   |
| F HOSE; HUMP 4"ID X 3"L       | 1    | 08418   |
| G INTAKE TUBE (AL)            | 1    | 27567TK |
| H GROMMET; 1"OD, 1/2"ID, 1/2" | 1    | 08064   |
| I BOLT; M4-.7 X 8MM           | 2    | 07733   |
| J HOSE; 4"ID TO 3.5"ID X 3"L  | 1    | 08497   |
| K HOSE CLAMP #56              | 1    | 08620   |
| L EDGE TRIM (39")             | 1    | 102496A |
| M ADAPTOR; #454               | 1    | 27300   |
| N HOSE CLAMP #104             | 1    | 08697   |
| O AIR FILTER                  | 1    | RU-1048 |
| P BLOCK OFF                   | 1    | 21508   |
| Q GASKET                      | 1    | 09076   |

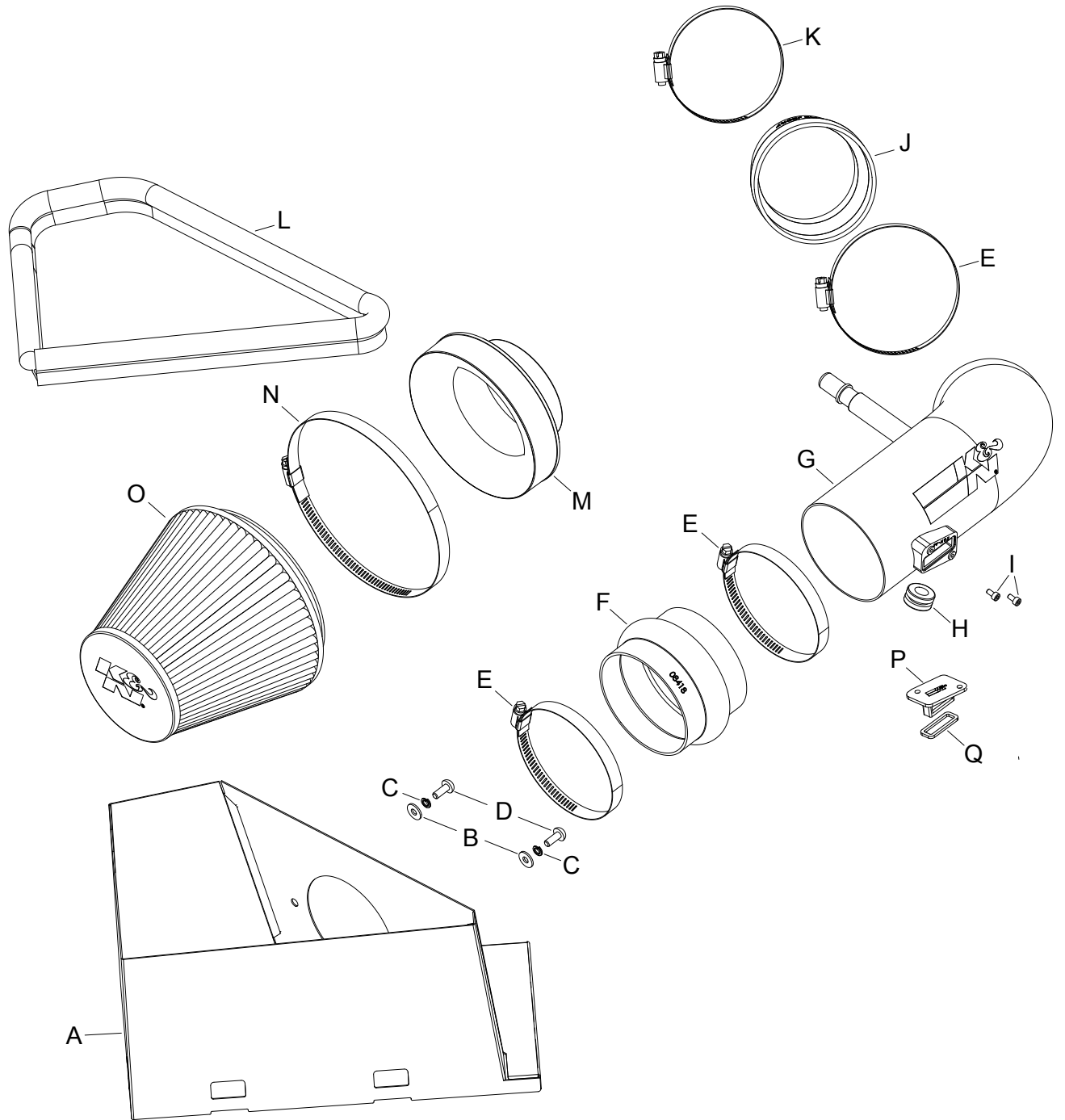

If you need any assistance please call 1-800-858-3333 to speak with a representative in our Customer Service Center before returning the product.

**NOTE: FAILURE TO FOLLOW INSTALLATION INSTRUCTIONS AND NOT USING THE PROVIDED HARDWARE MAY DAMAGE THE INTAKE TUBE, THROTTLE BODY AND ENGINE.**

#### TO START:

1. Turn off the ignition and disconnect the negative battery cable.

**NOTE: Disconnecting the negative battery cable erases pre-programmed electronic memories. Write down all memory settings before disconnecting the negative battery cable. Some radios will require an anti-theft code to be entered after the battery is reconnected. The anti-theft code is typically supplied with your owner's manual. In the event your vehicles anti-theft code cannot be recovered, contact an authorized dealership to obtain your vehicles anti-theft code.**



2. Lift up and remove the decorative engine cover.



3. Disconnect the inlet air temperature sensor and humidity sensor electrical connections.

**NOTE: Some vehicles may not be equipped with a humidity sensor.**



4. Depress the locking tab and then disconnect the crank case vent hose from the factory intake tube.



5. Loosen the hose clamp securing the factory intake tube to the throttle body.



6. Release the four locking tabs securing the air filter housing lid and then remove the housing lid and factory intake tube from the vehicle. Remove the factory air filter.

**NOTE: K&N Engineering, Inc., recommends that customers do not discard factory air intake.**



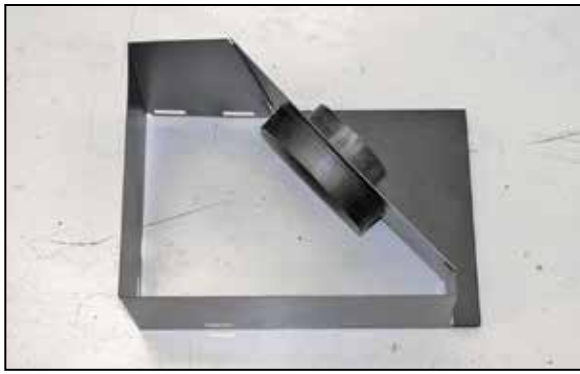

7. Install the filter adapter into the K&N® heat shield as shown and secure with the provided hardware.

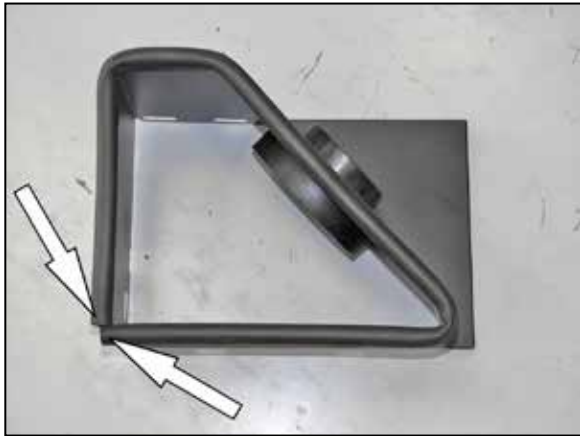

8. Install the provided edge trim onto the K&N® heat shield as shown.

**NOTE: Some trimming of the edge trim will be necessary.**



9. Install the K&N® air filter onto the filter adapter and secure with the provided hose clamp.

**NOTE: Drycharger® air filter wrap; part # RF-1048DK is available to purchase separately. To learn more about Drycharger® filter wraps or look up color availability please visit <http://www.knfilters.com>®.**



10. Install the heat shield/filter assembly onto the lower air filter housing and secure with the four factory lid retaining clips.



11. Remove the two screws securing the humidity sensor then remove the humidity sensor from the air filter housing. Remove the inlet air temperature sensor from the stock intake tube.

**NOTE: Some vehicles may not be equipped with a humidity sensor.**



12. Install the provided grommet into the intake tube as shown.



13. Remove the O-ring from the inlet air temperature sensor and then install the sensor into the grommet installed into the K&N® intake tube during the previous step.



14. Install the humidity sensor into the K&N® intake tube and secure with the provided hardware.

**NOTE: On vehicles not equipped with a humidity sensor, install the provided block off and gasket.**



15. Install the provided coupler hump hose (08418) onto filter adapter and secure with the provided hose clamp.



16. Install the provided step coupler (08497) onto the throttle body and secure with the provided hose clamps.



17. Install the K&N® intake tube into the hump coupler and then into the step coupler, then adjust the tube for best fit and secure with the provided hose clamps.



18. Connect the factory crankcase vent hose to the quick disconnect fitting on the K&N® intake tube.



19. Reconnect the humidity sensor and inlet air temperature sensor electrical connections.



20. Reconnect the vehicle's negative battery cable. Double check to make sure everything is tight and properly positioned before starting the vehicle.

21. The C.A.R.B. exemption sticker, (attached), must be visible under the hood so that an emissions inspector can see it when the vehicle is required to be tested for emissions. California requires testing every two years, other states may vary.

22. It will be necessary for all K&N® high flow intake systems to be checked periodically for realignment, clearance and tightening of all connections. Failure to follow the above instructions or proper maintenance may void warranty.

#### ROAD TESTING:

1. Start the engine with the transmission in neutral or park, and the parking brake engaged. Listen for air leaks or odd noises. For air leaks secure hoses and connections. For odd noises, find cause and repair before proceeding. This kit will function identically to the factory system except for being louder and much more responsive.

2. Test drive the vehicle. Listen for odd noises or rattles and fix as necessary.

3. If road test is fine, you can now enjoy the added power and performance from your kit.

4. K&N Engineering, Inc., requires cleaning the intake system's air filter element every 100,000 miles. When used in dusty or off-road environments, our filters will require cleaning more often. We recommend that you visually inspect your filter once every 25,000 miles to determine if the screen is still visible. When the screen is no longer visible some place on the filter element, it is time to clean it. To clean and re-oil, purchase our filter Recharger® service kit, part number 99-5050 or 99-5000 and follow the easy instructions.

**INTAKE SYSTEMS FOR VEHICLES LISTED ARE 50 STATE LEGAL. SEE KNFILTERS.COM FOR CARB STATUS ON EACH PART FOR A SPECIFIC VEHICLE.**